

***TB 9-6625-2263-35**

DEPARTMENT OF THE ARMY TECHNICAL BULLETIN

CALIBRATION PROCEDURE FOR DIGITAL MULTIMETER JOHN FLUKE, MODEL 8520A

Headquarters, Department of the Army, Washington, DC

13 August 2003

Approved for public release; distribution is unlimited

REPORTING OF ERRORS AND RECOMMENDING IMPROVEMENTS

You can improve this manual. If you find any mistakes or if you know of a way to improve these procedures, please let us know. Mail your letter or DA Form 2028 (Recommended Changes to Publications and Blank Forms) directly to: Commander, U.S. Army Aviation and Missile Command, ATTN: AMSAM-MMC-MA-NP, Redstone Arsenal, AL 35898-5000. A reply will be furnished to you. You may also provide DA Form 2028 information to AMCOM via email, fax, or the World Wide Web. Our fax number is DSN 788-6546 or Commercial 256-842-6546. Our e-mail address is: 2028@redstone.army.mil. Instructions for sending an electronic 2028 may be found at the back of this manual. For the World Wide Web, use <https://amcom2028.redstone.army.mil>.

SECTION		Paragraph	Page
	I. IDENTIFICATION AND DESCRIPTION		
	Test instrument identification	1	2
	Forms, records, and reports	2	2
	Calibration description	3	2
	II. EQUIPMENT REQUIREMENTS		
	Equipment required.....	4	3
	Accessories required.....	5	3
	III. CALIBRATION PROCESS		
	Preliminary instructions.....	6	5
	Equipment Setup.....	7	5
	Dc voltage	8	6
	Resistance.....	9	9
	Ac voltage.....	10	11
	Power supply.....	11	12
	Final procedure	12	13

**SECTION I
IDENTIFICATION AND DESCRIPTION**

1. Test Instrument Identification. This bulletin provides instructions for the calibration of Digital Multimeter, John Fluke, Model 8520A. The manufacturer’s manual was used as the prime data source in compiling these instructions. The equipment being calibrated will be referred to as the TI (test instrument) throughout this bulletin.

a. Model Variations. None.

b. Time and Technique. The time required for this calibration is approximately 2 hours, using the dc and low frequency technique.

2. Forms, Records, and Reports

a. Forms, records, and reports required for calibration personnel at all levels are prescribed by TB 750-25.

b. Adjustments to be reported are designated (R) at the end of the sentence in which they appear. When adjustments are in tables, the (R) follows the designated adjustment. Report only those adjustments made and designated with (R).

3. Calibration Description. TI parameters and performance specifications which pertain to this calibration are listed in table 1.

Table 1. Calibration Description

Test Instrument Parameters	Performance Specifications																							
Dc voltage	<table border="1" style="width: 100%; border-collapse: collapse;"> <thead> <tr> <th style="text-align: center;">Range</th> <th style="text-align: center;">Full-scale</th> <th style="text-align: center;">Accuracy ±(% of input + digits)</th> </tr> </thead> <tbody> <tr> <td style="text-align: center;">100 mV</td> <td style="text-align: center;">199.999</td> <td style="text-align: center;">0.011 + 10</td> </tr> <tr> <td style="text-align: center;">1 V</td> <td style="text-align: center;">1.99999</td> <td style="text-align: center;">0.011 + 2</td> </tr> <tr> <td style="text-align: center;">10 V</td> <td style="text-align: center;">16.0100</td> <td style="text-align: center;">0.009 + 1</td> </tr> <tr> <td style="text-align: center;">100 V</td> <td style="text-align: center;">130.100</td> <td style="text-align: center;">0.012 + 2</td> </tr> <tr> <td style="text-align: center;">1000 V</td> <td style="text-align: center;">1024.00</td> <td style="text-align: center;">0.011 + 1</td> </tr> </tbody> </table>			Range	Full-scale	Accuracy ±(% of input + digits)	100 mV	199.999	0.011 + 10	1 V	1.99999	0.011 + 2	10 V	16.0100	0.009 + 1	100 V	130.100	0.012 + 2	1000 V	1024.00	0.011 + 1			
Range	Full-scale	Accuracy ±(% of input + digits)																						
100 mV	199.999	0.011 + 10																						
1 V	1.99999	0.011 + 2																						
10 V	16.0100	0.009 + 1																						
100 V	130.100	0.012 + 2																						
1000 V	1024.00	0.011 + 1																						
Ac voltage	<table border="1" style="width: 100%; border-collapse: collapse;"> <thead> <tr> <th style="text-align: center;">Range</th> <th style="text-align: center;">Full-scale</th> <th style="text-align: center;">Accuracy¹ ±(% of input + % of FS)</th> </tr> </thead> <tbody> <tr> <td style="text-align: center;">1 V</td> <td style="text-align: center;">1.99999</td> <td style="text-align: center;">10 to 20 Hz 3.5 + 0.6</td> </tr> <tr> <td style="text-align: center;">10 V</td> <td style="text-align: center;">16.0100</td> <td style="text-align: center;">20 to 40 Hz 0.6 + 0.6</td> </tr> <tr> <td style="text-align: center;">100 V</td> <td style="text-align: center;">130.100</td> <td style="text-align: center;">40 Hz to 20 kHz 0.15 + 0.05</td> </tr> <tr> <td style="text-align: center;">650 V</td> <td style="text-align: center;">650.00</td> <td style="text-align: center;">20 to 100 kHz 2.0 + 0.6</td> </tr> <tr> <td></td> <td></td> <td style="text-align: center;">100 to 300 kHz 4.0 + 1.0</td> </tr> <tr> <td></td> <td></td> <td style="text-align: center;">300 kHz to 1 MHz 15.0 + 5.0</td> </tr> </tbody> </table>			Range	Full-scale	Accuracy ¹ ±(% of input + % of FS)	1 V	1.99999	10 to 20 Hz 3.5 + 0.6	10 V	16.0100	20 to 40 Hz 0.6 + 0.6	100 V	130.100	40 Hz to 20 kHz 0.15 + 0.05	650 V	650.00	20 to 100 kHz 2.0 + 0.6			100 to 300 kHz 4.0 + 1.0			300 kHz to 1 MHz 15.0 + 5.0
Range	Full-scale	Accuracy ¹ ±(% of input + % of FS)																						
1 V	1.99999	10 to 20 Hz 3.5 + 0.6																						
10 V	16.0100	20 to 40 Hz 0.6 + 0.6																						
100 V	130.100	40 Hz to 20 kHz 0.15 + 0.05																						
650 V	650.00	20 to 100 kHz 2.0 + 0.6																						
		100 to 300 kHz 4.0 + 1.0																						
		300 kHz to 1 MHz 15.0 + 5.0																						

See footnotes at end of table.

Table 1. Calibration Description - Continued

Resistance			Accuracy ±(% of input + digits)
	Range	Full-scale	
	10 Ω	19.9999	0.0140 + 12
	100 Ω	199.999	0.0125 + 3
	1000 Ω	1999.99	0.0125 + 3
	10 kΩ	19.9999	0.0125 + 3
	100 kΩ	199.999	0.0140 + 3
	1 MΩ	1.99999	0.0200 + 3
10 MΩ	19.999	0.0450 + 3	
Conductance	Range: 100 nS Full scale: 202.00 nS Accuracy: ±(0.06% of input + 5 digits)		

¹From 0.1% of range to FS. For 650 V range multiply % of FS by 1.6. Maximum Volts-Hertz product is 2 X 10⁷.

**SECTION II
EQUIPMENT REQUIREMENTS**

4. Equipment Required. Table 2 identifies the specific equipment to be used in this calibration procedure. This equipment is issued with Secondary Transfer Calibration Standards Set AN/GSM-286. Alternate items may be used by the calibrating activity. The items selected must be verified to perform satisfactorily prior to use and must bear evidence of current calibration. The equipment must meet or exceed the minimum use specifications listed in table 2. The accuracies listed in table 2 provide a four-to-one ratio between the standard and TI.

5. Accessories Required. The accessories required for the calibration are common usage accessories, issued as indicated in paragraph 4 above, and are not listed in this calibration procedure.

Table 2. Minimum Specifications of Equipment Required

Common name	Minimum use specifications	Manufacturer and model (part number)	
CALIBRATOR	Dc voltage: Range: -8.1 to +1000 V Accuracy: ±0.0025%	John Fluke, Model 5720A (p.o MIS-35947), w/power amplifier, John Fluke, Model 5725A (5725A)	
	Resistance:		
	Range		Accuracy (±%)
	0Ω		300 μΩ
	10Ω		0.006
	100Ω, 1 kΩ, 10 kΩ		0.004
	100 kΩ		0.004
	1 MΩ		0.006
10 MΩ	0.019		

TB 9-6625-2263-35

Table 2. Minimum Specifications of Equipment Required - Continued

Common name	Minimum use specifications	Manufacturer and model (part number)																																																																								
<p>CALIBRATOR (continued)</p>	<p>Ac voltage:</p> <table border="1" data-bbox="509 401 1013 1245"> <thead> <tr> <th>Range</th> <th>Frequency</th> <th>Accuracy ±(%)</th> </tr> </thead> <tbody> <tr><td>1 V</td><td>15 Hz</td><td>1.18</td></tr> <tr><td>1 V</td><td>30 Hz</td><td>0.45</td></tr> <tr><td>1 V</td><td>200 Hz</td><td>0.0625</td></tr> <tr><td>1 V</td><td>15 kHz</td><td>0.0625</td></tr> <tr><td>1 V</td><td>90 kHz</td><td>0.8</td></tr> <tr><td>1 V</td><td>200 kHz</td><td>1.5</td></tr> <tr><td>1 V</td><td>1 MHz</td><td>6.25</td></tr> <tr><td>10 V</td><td>15 Hz</td><td>1.12</td></tr> <tr><td>10 V</td><td>30 Hz</td><td>0.39</td></tr> <tr><td>10 V</td><td>200 Hz</td><td>0.058</td></tr> <tr><td>10 V</td><td>15 kHz</td><td>0.058</td></tr> <tr><td>10 V</td><td>90 kHz</td><td>0.74</td></tr> <tr><td>10 V</td><td>200 kHz</td><td>1.4</td></tr> <tr><td>10 V</td><td>1 MHz</td><td>5.75</td></tr> <tr><td>50 V</td><td>200 kHz</td><td>1.65</td></tr> <tr><td>100 V</td><td>15 Hz</td><td>1.07</td></tr> <tr><td>100 V</td><td>30 Hz</td><td>0.345</td></tr> <tr><td>100 V</td><td>200 Hz</td><td>0.538</td></tr> <tr><td>100 V</td><td>15 kHz</td><td>0.538</td></tr> <tr><td>100 V</td><td>90 kHz</td><td>0.718</td></tr> <tr><td>600 V</td><td>200 Hz</td><td>0.059</td></tr> <tr><td>600 V</td><td>15 kHz</td><td>0.059</td></tr> <tr><td>600 V</td><td>30 kHz</td><td>0.76</td></tr> </tbody> </table>	Range	Frequency	Accuracy ±(%)	1 V	15 Hz	1.18	1 V	30 Hz	0.45	1 V	200 Hz	0.0625	1 V	15 kHz	0.0625	1 V	90 kHz	0.8	1 V	200 kHz	1.5	1 V	1 MHz	6.25	10 V	15 Hz	1.12	10 V	30 Hz	0.39	10 V	200 Hz	0.058	10 V	15 kHz	0.058	10 V	90 kHz	0.74	10 V	200 kHz	1.4	10 V	1 MHz	5.75	50 V	200 kHz	1.65	100 V	15 Hz	1.07	100 V	30 Hz	0.345	100 V	200 Hz	0.538	100 V	15 kHz	0.538	100 V	90 kHz	0.718	600 V	200 Hz	0.059	600 V	15 kHz	0.059	600 V	30 kHz	0.76	
Range	Frequency	Accuracy ±(%)																																																																								
1 V	15 Hz	1.18																																																																								
1 V	30 Hz	0.45																																																																								
1 V	200 Hz	0.0625																																																																								
1 V	15 kHz	0.0625																																																																								
1 V	90 kHz	0.8																																																																								
1 V	200 kHz	1.5																																																																								
1 V	1 MHz	6.25																																																																								
10 V	15 Hz	1.12																																																																								
10 V	30 Hz	0.39																																																																								
10 V	200 Hz	0.058																																																																								
10 V	15 kHz	0.058																																																																								
10 V	90 kHz	0.74																																																																								
10 V	200 kHz	1.4																																																																								
10 V	1 MHz	5.75																																																																								
50 V	200 kHz	1.65																																																																								
100 V	15 Hz	1.07																																																																								
100 V	30 Hz	0.345																																																																								
100 V	200 Hz	0.538																																																																								
100 V	15 kHz	0.538																																																																								
100 V	90 kHz	0.718																																																																								
600 V	200 Hz	0.059																																																																								
600 V	15 kHz	0.059																																																																								
600 V	30 kHz	0.76																																																																								
<p>MULTIMETER</p>	<p>Range: 4.9 to 5.2 V dc Accuracy: ±0.74%</p>	<p>John Fluke, Model 8840A/AF-05 (AN/GSM-64D)</p>																																																																								
<p>RESISTANCE STANDARD</p>	<p>Range: 10 MΩ Accuracy: ±0.0275%</p>	<p>Beckman, Model CR10M (8598965)</p>																																																																								

SECTION III CALIBRATION PROCESS

6. Preliminary Instructions

a. The instructions outlined in paragraphs **6** and **7** are preparatory to the calibration process. Personnel should become familiar with the entire bulletin before beginning the calibration.

b. Items of equipment used in this procedure are referenced within the text by common name as listed in table 2.

c. Unless otherwise specified, verify the result of each test and, whenever the test requirement is not met, take corrective action before continuing with the calibration. Adjustments required to calibrate the TI are included in this procedure. Additional maintenance information is contained in the manufacturer's manual for this TI.

d. When indications specified in paragraphs **8** through **10** are not within tolerance, perform the power supply check prior to making adjustments. After adjustments are made, repeat paragraphs **8** through **10**. Do not perform power supply check if all other parameters are within tolerance.

e. Unless other specified, all controls are control settings refer to the TI.

7. Equipment Setup

WARNING

HIGH VOLTAGE is used or exposed during the performance of this calibration. DEATH ON CONTACT may result if personnel fail to observe safety precautions. REDUCE OUTPUT(S) to minimum after each step within the performance check where available.

a. Remove protective covers from TI only when necessary to make adjustments. Replace cover after completing the adjustments.

b. Connect TI to a 115 V ac source.

c. Release **INPUT REAR/FRONT** pushbutton to **FRONT**, and **EXTERNAL GUARD/NORMAL** pushbutton to **NORMAL**.

d. Press **POWER ON/OFF** pushbutton to **ON** and allow at least 2 hours for warm-up.

TB 9-6625-2263-35

8. Dc Voltage

a. Performance Check

(1) Press **VDC** pushbutton and **RANGE D** or **Ñ** pushbutton to select 100 mVDC range.

(2) Short TI **V/W INPUT HI** and **LO**. If TI does not indicate between -.010 and +.010 mVDC, perform **b(1)** through **(4)** below.

(3) Remove short and connect calibrator **OUTPUT HI** and **LO** to TI **V/W INPUT HI** and **LO**.

(4) Set calibrator for a 100 mV dc output. If TI does not indicate between 99.979 and 100.021 mVDC, perform **b(5)** below.

(5) Repeat technique of (1) and (4) above for TI and calibrator settings listed in table 3. If TI does not indicate within limits specified, perform adjustments listed in table 3.

Table 3. Dc Voltage

Test instrument range settings (VDC)	Calibrator output settings (V)	Test instrument			
		Indications VDC		Adjustments ¹	
		Min	Max		
1	1	.99987	1.00013	b(6) through b(8)	
10	1	.9998	1.0002	b(9) through b(20)	
10	2	1.9997	2.0003	b(9) through b(20)	
10	4	3.9995	4.0005	b(9) through b(20)	
10	8	7.9992	8.0008	b(9) through b(20)	
10	- 8	-7.9992	-8.0008	b(9) through b(20)	
10	10	9.9990	10.0010	b(9) through b(20)	
100	100	99.986	100.014	b(21) through b(23)	
1000	1000	999.88	1000.12	---	

¹If adjustments are made, verify all checks affected by each adjustment.

b. Adjustments

(1) Adjust DC BUFFER C231 SLOW DC (fig. 1) for TI indication between -.001 and +.001 mVDC (R).

(2) Press **READING RATE D** or **Ñ** pushbutton to select **10/SEC** rate.

(3) Adjust DC BUFFER C225 FAST DC (fig. 1) for TI indication of .000 mVDC with the + and - signs alternating (R).

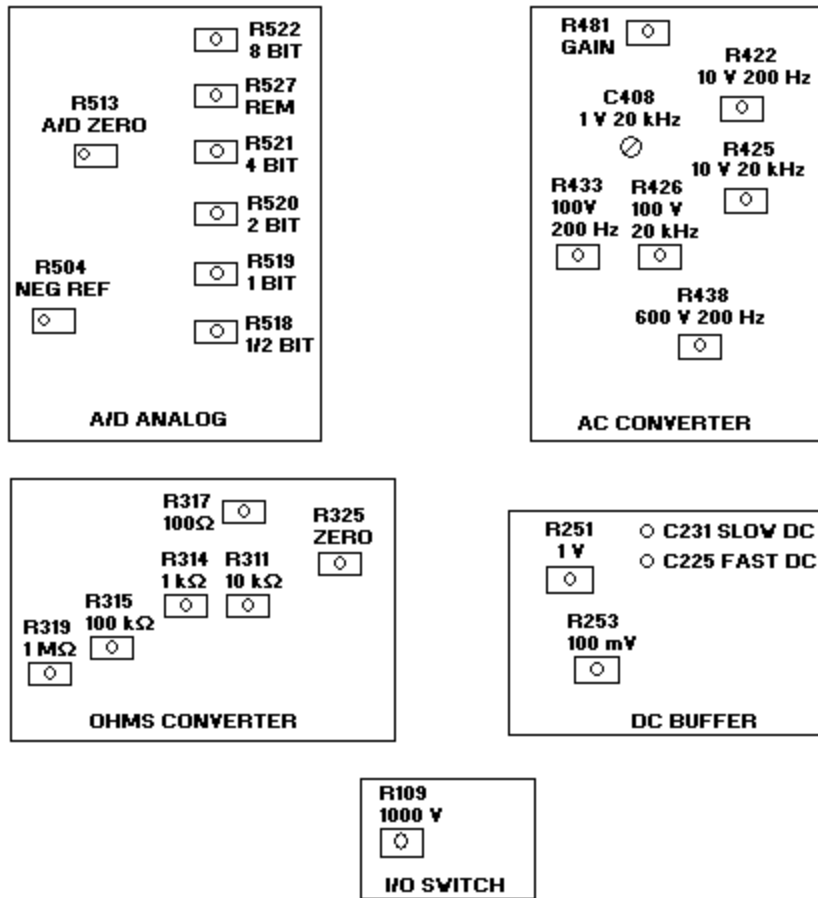

Figure 1. Adjustment locations.

- (4) Press **READING RATE** D or \tilde{N} pushbutton to select **10/SEC** rate.
- (5) Set calibrator for a 190 mV output. Adjust DC BUFFER R253 100 mV (fig. 1) for TI indication between 189.998 and 190.002 mVDC (R).
- (6) Press S1 (fig. 2) to select cal digit mode.

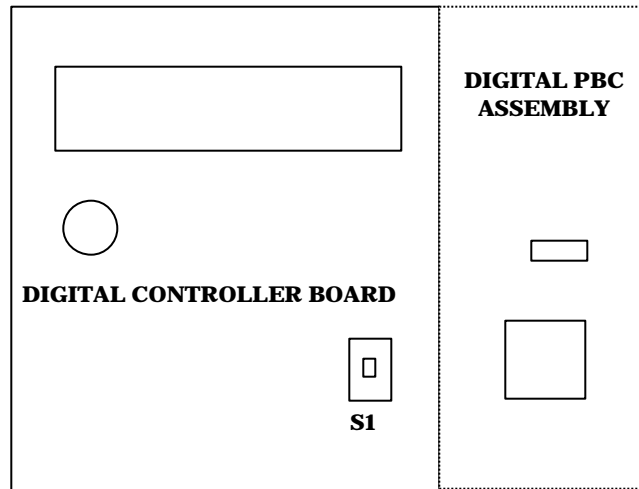

Figure 2. Cal digit switch - S1 location.

- (7) Set calibrator for a 1.9 V output. Adjust DC BUFFER R251 1V (fig. 1) for TI indication between 1.89999 4 and 1.90000 6 VD (R).
- (8) Press S1 (fig. 2) to return to normal mode.
- (9) Press S1 (fig. 2) to select cal digit mode.
- (10) Set calibrator to **STANDBY** and disconnect calibrator from TI.
- (11) Short TI **V/W INPUT HI** and **LO**. Adjust A/D ANALOG R513 A/D ZERO (fig. 1) for TI indication between -.0000 2 and +.0000 2 VD (R).
- (12) Remove short and connect calibrator **OUTPUT HI** and **LO** to TI **V/W INPUT HI** and **LO**.
- (13) Set calibrator for a -8.1 V output. Adjust A/D ANALOG R522 8 BIT (fig. 1) for TI indication between -8.0999 8 and -8.1000 2 VD (R).
- (14) Set calibrator for a +8.1 V output. Adjust A/D ANALOG R504 NEG REF (fig. 1) for TI indication between 8.0999 8 and 8.1000 2 VD (R).
- (15) Set calibrator for a 4.1 V output. Adjust A/D ANALOG R521 4 BIT (fig. 1) for TI indication between 4.0999 8 and 4.1000 2 VD (R).
- (16) Set calibrator for a 2.1 V output. Adjust A/D ANALOG R520 2 BIT (fig. 1) for TI indication between 2.0999 8 and 2.1000 2 VD (R).
- (17) Set calibrator for a 1.1 V output. Adjust A/D ANALOG R519 1 BIT (fig. 1) for TI indication between 1.0999 8 and 1.1000 2 VD (R).
- (18) Set calibrator for a .6 V output. Adjust A/D ANALOG R518 1/2 BIT (fig. 1) for TI indication between .5999 8 and .6000 2 VD (R).

(19) Set calibrator for a .3 V output. Adjust A/D ANALOG R527 REM (fig. 1) for TI indication between .2999 8 and .3000 2 VD (R).

(20) Press S1 (fig 2) to return to normal mode.

(21) Press S1 (fig. 2) to select cal digit mode.

(22) Set calibrator for a 120 V output. Adjust I/O SWITCH R109 1000 V (fig. 1) for TI indication between 119.999 4 and 120.000 6 VD (R).

(23) Press S1 (fig. 2) to return to normal mode.

9. Resistance

a. Performance Check

(1) Press **W4-WIRE** pushbutton and **RANGE D** or \tilde{N} pushbutton to select 10 Ω range.

(2) Press **READING RATE D** or \tilde{N} pushbutton to select **1/SEC** rate.

(3) Connect calibrator **OUTPUT HI** and **LO** to TI **V/W INPUT HI** and **LO**.

(4) Connect calibrator **SENSE HI** and **LO** to TI **W SOURCE HI** and **LO**.

(5) Set calibrator for a 0 Ω output, **EX SNS** on and **2 wire Comp** off. If TI does not indicate .0000 Ω \pm 12 digits, perform **b**(1) through (4) below.

(6) Press **READING RATE D** or \tilde{N} pushbutton to select **2/SEC** rate.

(7) Set calibrator for a 10 Ω output then, using calibrator output adjustment controls, set calibrator control display **Reading** equal to TI indication. Calibrator control display **Error** will indicate within \pm 0.026 %.

(8) Repeat technique of (1) and (7) above for TI and calibrator settings listed in table 4. If calibrator control **Error** display does not indicate within limits specified, perform adjustments listed in table 4.

Table 4. Resistance

Test instrument range settings (Ω)	Calibrator		Test instrument adjustments
	Output settings (Ω)	Control display Error indications \pm (%)	
100	100	0.0155	b(5) through b(7)
1 k	1 k	0.0155	b(8) through b(10)
10 k	10 k	0.0155	b(11) through b(13)
100 k	100 k	0.017	b(14) through b(18)
1 M	1 M	0.023	b(19) through b(25)
10 M ¹	10 M	0.075	- - -

¹On some TIs the decimal point may align with 100 on the front panel when in the 10 M Ω range.

(9) Set calibrator to **STANDBY** and disconnect from TI. Connect resistance standard set for 10 M Ω to TI **VW/INPUT HI** and **LO**.

(10) Press **nS** pushbutton. TI will indicate between 99.89 and 100.11 nS.

TB 9-6625-2263-35

b. Adjustments

- (1) Press **READING RATE** D or \tilde{N} pushbutton to select **2/SEC** rate.
- (2) Press S1 (fig. 2) to select cal digit mode.
- (3) Adjust OHMS CONVERTER R325 ZERO (fig. 1) for TI indication of -.0000 0 ± 20 cal digits (R).
- (4) Press S1 (fig. 2) to return to normal mode.
- (5) Press S1 (fig. 2) to select cal digit mode.
- (6) Adjust OHMS CONVERTER R317 100 Ω (fig. 1) for TI indication equal to calibrator output display rounded to TI digits of resolution ± 15 cal digits (R).
- (7) Press S1 (fig. 2) to return to normal mode.
- (8) Press S1 (fig. 2) to select cal digit mode.
- (9) Adjust OHMS CONVERTER R314 1 k Ω (fig. 1) for a TI indication equal to calibrator output display rounded to TI digits of resolution ± 15 cal digits (R).
- (10) Press S1 (fig. 2) to return to normal mode.
- (11) Press S1 (fig. 2) to select cal digit mode.
- (12) Adjust OHMS CONVERTER R311 10 k Ω (fig. 1) for TI indication equal to calibrator output display rounded to TI digits of resolution ± 15 cal digits (R).
- (13) Press S1 (fig. 2) to return to normal mode.
- (14) Press **W2-WIRE** pushbutton and set calibrator **EX SNS** off.
- (15) Press S1 (fig. 2) to select cal digit mode.
- (16) Adjust OHMS CONVERTER R315 100 k Ω (fig. 1) for TI indication equal to calibrator output display rounded to TI digits of resolution ± 15 cal digits (R).
- (17) Press **W4-WIRE** pushbutton and set calibrator **EX SNS** on.
- (18) Press S1 (fig. 2) to return to normal mode.
- (19) Press **W2-WIRE** pushbutton and set calibrator **EX SNS** off.
- (20) Press **READING RATE** D or \tilde{N} pushbutton to select **1/SEC** rate and **FILTER** D or \tilde{N} pushbutton to select **SLOW** filter.
- (21) Press S1 (fig. 2) to select cal digit mode.
- (22) Adjust OHMS CONVERTER R319 1 M Ω (fig. 1) for TI indication equal to calibrator output display rounded to TI digits of resolution ± 20 cal digits (R).
- (23) Press **READING RATE** D or \tilde{N} pushbutton to select **2/SEC** rate and **FILTER** D or \tilde{N} pushbutton to select **FAST** filter.
- (24) Press **W4-WIRE** pushbutton and set calibrator **EX SNS** on.
- (25) Press S1 (fig. 2) to return to normal mode.

10. Ac Voltage

a. Performance Check

- (1) Connect calibrator **OUTPUT HI** and **LO** to TI **V/W INPUT HI** and **LO**.
- (2) Press **VAC** pushbutton.
- (3) Press **RANGE D** or **Ñ** pushbutton to select TI range settings and set calibrator for output settings listed in table 5. If TI does not indicate within limits specified, perform adjustments listed in table 5.

Table 5. Ac Voltage

Test instrument range settings (VAC)	Calibrator output settings		Test instrument		
			Indications VAC		Adjustments ¹
	Voltage	Frequency	Min	Max	
1	1 V	15 Hz	0.953	1.047	b(1)
1	1 V	30 Hz	0.982	1.018	b(1)
1	1 V	200 Hz	0.9975	1.0025	b(1)
1	1 V	15 kHz	0.9975	1.0025	b(2)
1	1 V	90 kHz	0.968	1.032	b(2)
1	1 V	200 kHz	0.94	1.06	b(2)
1	1 V	1 MHz	0.75	1.25	b(2)
10	10 V	1 MHz	7.6995	12.3005	b(3)
10	10 V	200 kHz	9.4399	10.5601	b(3)
10	10 V	90 kHz	9.7039	10.2961	b(3)
10	10 V	15 kHz	9.9852	10.023	b(3)
10	10 V	200 Hz	9.9852	10.023	b(4)
10	10 V	30 Hz	9.8439	10.1561	b(4)
10	10 V	15 Hz	9.5539	10.4461	b(4)
100	100 V	15 Hz	95.719	104.281	b(5)
100	100 V	30 Hz	98.619	101.381	b(5)
100	100 V	200 Hz	99.785	100.215	b(5)
100	100 V	15 kHz	99.785	100.215	b(6)
100	100 V	90 kHz	97.129	102.871	b(6)
100	50 V	200 kHz	46.699	53.301	---
1000	600 V	200 Hz	598.58	601.42	b(7)
1000	600 V	15 kHz	598.58	601.42	---
1000	600 V	30 kHz	581.76	618.24	---
1000	100 V	90 kHz	91.76	108.24	---

¹If adjustments are made, verify all checks affected by each adjustment.

b. Adjustments

- (1) Set calibrator for a 1.6 V, 200 Hz output. Adjust AC CONVERTER R481 GAIN (fig. 1) for TI indication between 1.59992 and 1.60008 VAC (R).
- (2) Set calibrator for a 1.6 V, 20 kHz output. Adjust AC CONVERTER C408 1 V 20 kHz (fig. 1) for TI indication between 1.5988 and 1.60012 VAC (R).

TB 9-6625-2263-35

(3) Set calibrator for a 11 V, 20 kHz output. Adjust AC CONVERTER R425 10 V 20 kHz (fig. 1) for TI indication between 10.9988 and 11.0012 VAC (R).

(4) Set calibrator for a 11 V, 200 Hz output. Adjust AC CONVERTER R422 10 V 200 Hz (fig. 1) for TI indication between 10.9994 and 11.0006 VAC (R).

(5) Set calibrator for a 100 V, 200 Hz output. Adjust AC CONVERTER R433 100 V 200 Hz (fig. 1) for TI indication between 99.994 and 100.006 VAC (R).

(6) Set calibrator for a 100 V, 20 kHz output. Adjust AC CONVERTER R426 100 V 20 kHz (fig. 1) for TI indication between 109.988 and 110.012 VAC (R).

(7) Set calibrator for a 600 V, 200 Hz output. Adjust AC CONVERTER R438 600 V 200 Hz (fig. 1) for TI indication between 599.94 and 600.06 VAC (R).

11. Power Supply

a. Performance Check

NOTE

Do not perform power supply checks if all other parameters are in tolerance.

(1) Connect multimeter **INPUT HI** to TP201 VCC and **LO** to TP202 VSS (fig. 3). If multimeter does not indicate between +4.9 and +5.2 V dc, perform **b(1)** below.

(2) Connect multimeter **INPUT HI** to TP701 and **LO** to TP702 (fig. 3). If multimeter does not indicate between +4.9 and +5.2 V dc, perform **b(2)** below.

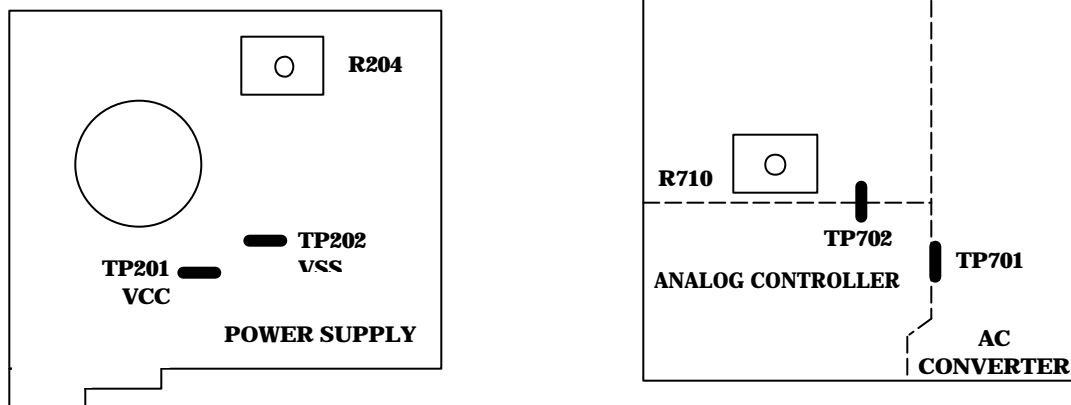

Figure 3. Power supply - adjustment locations.

b. Adjustments

(1) Adjust R204 (fig. 3) for a multimeter indication between +4.9 and +5.2 V dc (R).

(2) Adjust R710 (fig. 3) for a multimeter indication between +4.9 and +5.2 V dc (R).

12. Final Procedure

a. Deenergize and disconnect all equipment.

b. Annotate and affix DA label/form in accordance with TB 750-25.

TB 9-6625-2263-35

By Order of the Secretary of the Army:

Official:

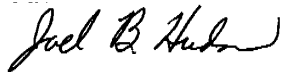

JOEL B. HUDSON

*Administrative Assistant to the
Secretary of the Army*

0316304

JOHN M. KEANE
*General, United States Army
Acting Chief of Staff*

Distribution:

To be distributed in accordance with IDN 344374, requirements for calibration procedure
TB 9-6625-2263-35.

Instructions for Submitting an Electronic 2028

The following format must be used if submitting an electronic 2028. The subject line must be exactly the same and all fields must be included; however, only the following fields are mandatory: 1, 3, 4, 5, 6, 7, 8, 9, 10, 13, 15, 16, 17, and 27.

From: "Whomever" whomever@redstone.army.mil

To: <2028@redstone.army.mil

Subject: DA Form 2028

1. **From:** Joe Smith
2. Unit: home
3. **Address:** 4300 Park
4. **City:** Hometown
5. **St:** MO
6. **Zip:** 77777
7. **Date Sent:** 19-OCT -93
8. **Pub no:** 55-2840-229-23
9. **Pub Title:** TM
10. **Publication Date:** 04-JUL-85
11. Change Number: 7
12. Submitter Rank: MSG
13. **Submitter FName:** Joe
14. Submitter MName: T
15. **Submitter LName:** Smith
16. **Submitter Phone:** 123-123-1234
17. **Problem:** 1
18. Page: 2
19. Paragraph: 3
20. Line: 4
21. NSN: 5
22. Reference: 6
23. Figure: 7
24. Table: 8
25. Item: 9
26. Total: 123
27. **Text**

This is the text for the problem below line 27.

PIN NO: 069374-000